

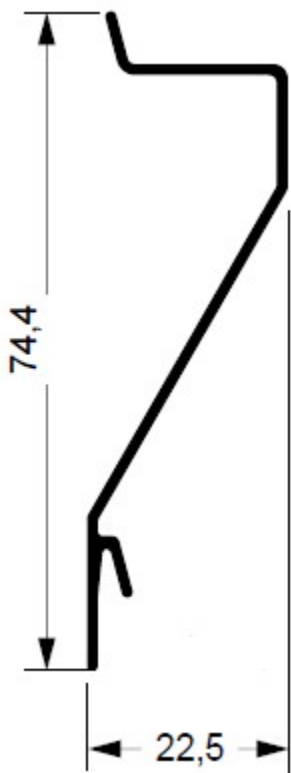

CAMAL ALUMÍNIO |||

PALHETAS



VZ-006 - CEGA

0,329 kg/m

Z-203F - VAZADA

0,329 kg/m

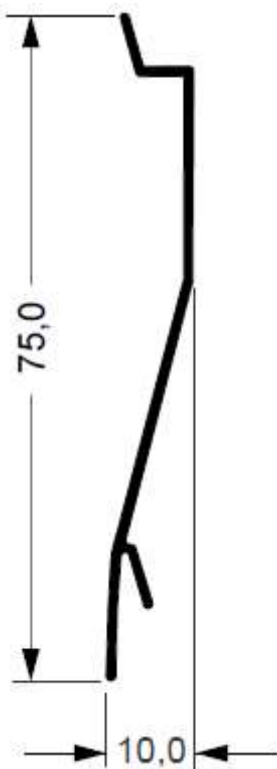

Z-201 - CEGA

0,261 kg/m

Z-201F - VAZADA

0,261 kg/m

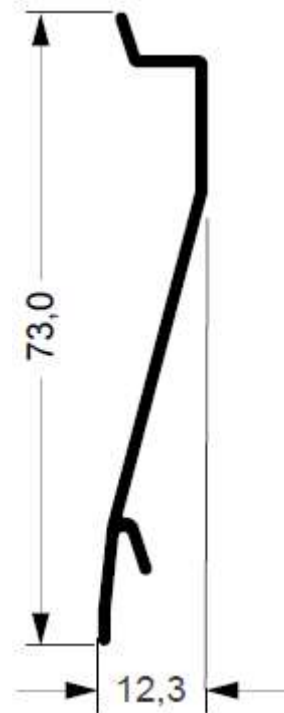

VZ051 - CEGA

0,266 kg/m

US-294 - VAZADA

0,266 kg/m

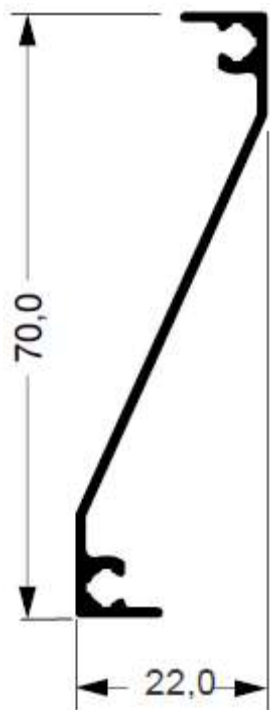

VZ-005

0,368 kg/m

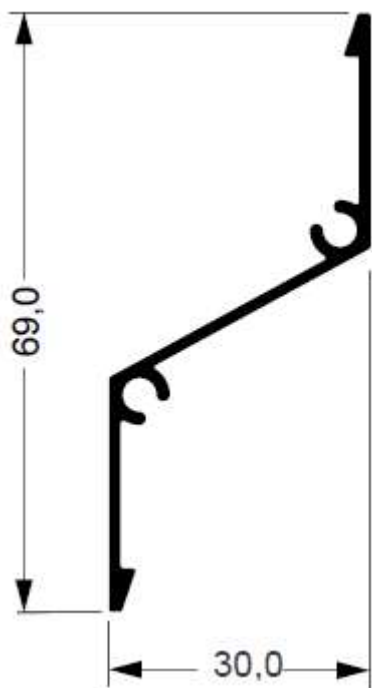

VZ-060

0,397 kg/m

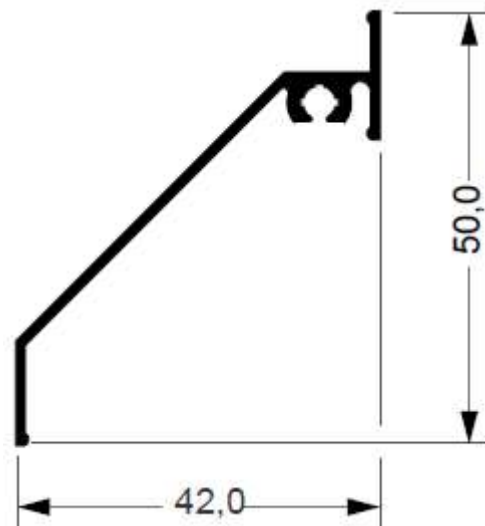

VZ-047

0,305 kg/m